

## 2012 - 2013 Jeep Wrangler 3.6L Delete Pipe

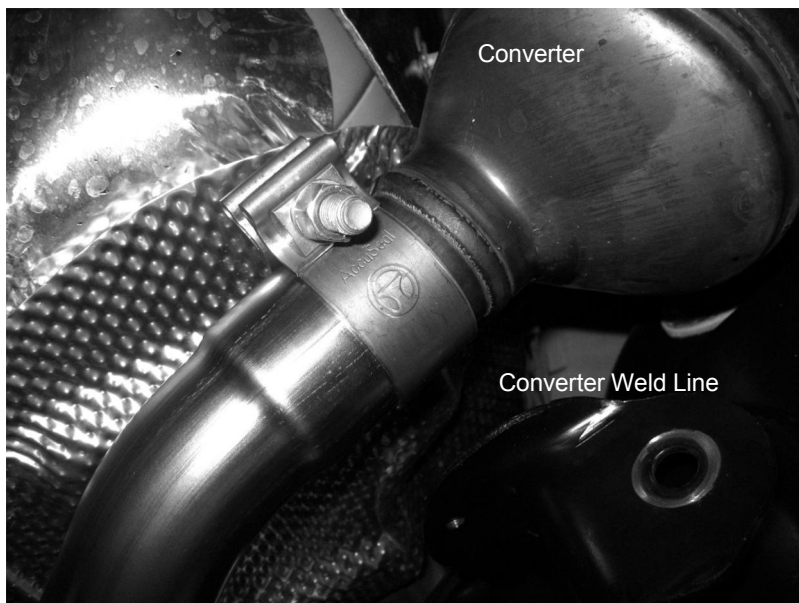
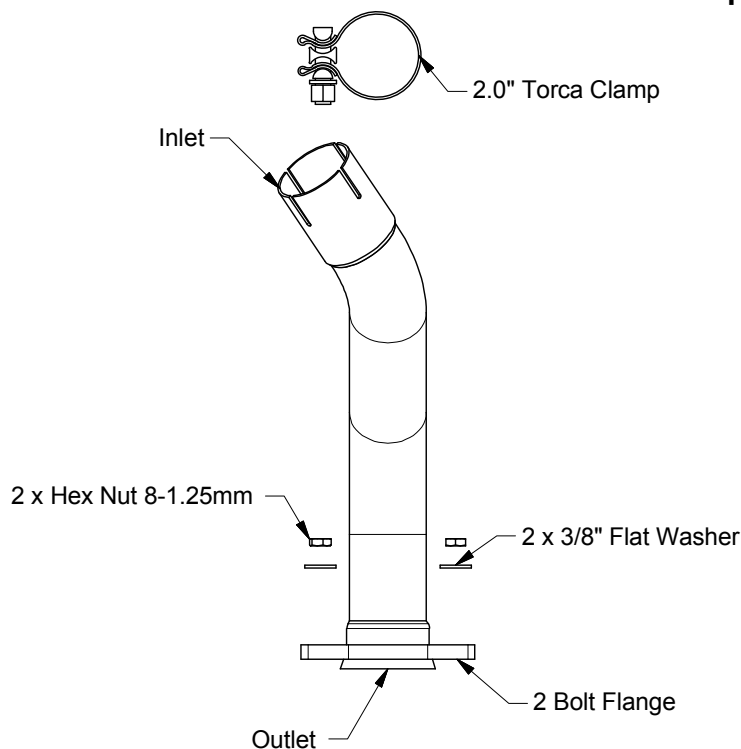

Fig. #1

**\*\* Magnaflow Performance Exhaust recommends professional installation on all their products**

**Warning:** When working on, under, or around any vehicle exercise caution. Please allow the vehicle's exhaust system to cool before removal, as exhaust system temperatures may cause severe burns. If working without a lift, always consult vehicle manual for correct lifting specifications. Always wear safety glasses and ensure a safe work area. Serious injury or death could occur if safety measures are not followed.

**Step 1:** (Carefully read all instructions before installation) Measure and mark the OEM Looped Pipe 3.00" behind the Converter Weld Line shown in Fig. #1.

**Step 2:** With the OEM Looped Pipe still attached at the Flange cut at the measured line. Un-bolt flange and remove the OEM Looped Pipe from the system.

**Step 3:** Slip the inlet end of the new Magnaflow extension pipe over the cut converter outlet. Loosely secure using the supplied clamp. Next loosely attach the outlet using the supplied flange, nuts and washers to the existing bolts.

**Step 4:** With all components mounted loosely, adjust the system for overall aesthetics and clearance of frame & bodywork. (MAGNAFLOW recommends at least 1/2" of clearance between the exhaust system and any body panels to prevent heat-related body damage or fire.)

**Step 5:** Once a final position has been chosen for the new system, evenly tighten all fasteners from front to rear. The supplied band clamps must be VERY tight to properly align the pipes and prevent leaks (Approximately 40ft-lbs). U-bolt clamps should be tightened to approximately 30-35ft-lbs. Inspect all fasteners after 25-50 miles of operation and retighten if necessary.