

with Installation Instructions
Owner's Manual

**Banks
PowerPack®
System**

Including:

**Banks Stinger® System &
Optional Ottomind®**

Ford 6.8L V-10 Class-C Motorhome

THIS MANUAL IS FOR USE WITH SYSTEM 49144, 49145, 49148, 49156-49159,
49185-49189

Gale Banks Engineering
546 Duggan Avenue • Azusa, CA 91702
(626) 969-9600 • Fax (626) 334-1743

Product Information & Sales: (888) 635-4565

bankspower.com

General Installation Practices

Dear Customer,

If you have any questions concerning the installation of your Banks Power System, please call our Technical Service Hotline at (888) 839-2700 between 7:00 am and 5:00 pm (PT). If you have any questions relating to shipping or billing, please contact our Customer Service Department at (888) 839-5600.

Thank you.

1. For ease of installation of your Banks system, familiarize yourself with the procedure by reading the entire manual before starting work.
2. The exploded views provide only general guidance. Refer to each step and section diagram in this manual for proper instruction.
3. Throughout this manual, the left side of the vehicle refers to the driver's side, and the right side to the passenger's side.
4. Disconnect the ground cables from the battery before beginning work. If the vehicle has more than one battery, be sure that the engine primary battery is disconnected. This is necessary for safety and to ease the installation of the passenger side TorqueTube® exhaust manifold.
5. Route and tie wires and hoses a minimum of 6 inches away from exhaust heat, moving parts and sharp edges. Clearance of 8 inches or more is recommended where possible.

6. When raising the vehicle, support it on properly weight-rated safety stands, ramps or a commercial hoist. Follow the manufacturer's safety precautions. Take care to balance the vehicle to prevent it from slipping or falling. When using ramps, be sure the front wheels are centered squarely on the topsides; put the transmission in park; set the hand brake; and place blocks behind the rear wheels. If the vehicle is supported by a hoist, the front wheels may be removed for further accessibility.

CAUTION! Do not use floor jacks to support the vehicle while working under it. Do not raise the vehicle onto concrete blocks, masonry or any other item not intended specifically for this use.

7. During installation, keep the work area clean. If foreign debris is transferred to any Banks component. Clean it thoroughly before installing.

Warning! Never work under any vehicle supported only by a jack of any kind. DO NOT USE concrete blocks or other masonry items that may collapse under the vehicle weight.

Notification

The Banks Ram-Air Filter comes pre-oiled and no oiling is necessary for initial installation. Service the filter as specified in the Cleaning and Oiling the Banks Ram-Air Filter Section of this manual.

Tools Required

- 1 1/4" wrench
- 5mm 6 point socket
- Chisel or hacksaw
- Saw or torch
- Clean shop towels or rags
- Pry bar or channel lock pliers
- 1/4" and 3/8" drive ratchets with metric sockets and a 1/4" drive extension
- Metric combination or open-end wrenches
- Standard and Phillips head screwdrivers
- Penetrating oil or light lubricant spray
- Standard and phillips head screwdrivers

Tools Optional

- Tailpipe expander

Table of Contents

General Assembly	4
Section 1	7
Torquetube Manifolds	
Section 2	10
Ram-Air® Intake	
Section 3	11
Monster® Exhaust	
Section 4	12
Cleaning and Oiling the Banks Ram-Air Filter	

General Assembly

Figure 1 (49144 System Shown)

Item #	Part #		QTY
1	53005	TORQUE TUBE, LEFT	1
2	53006	TORQUE TUBE, RIGHT	1
3	53105	Y-PIPE	1
4	53106	Y-PIPE EXTENSION	1
5	52405	DYNAFLOW MUFFLER	1
6	52956	MONSTER TAILPIPE, RIGHT EXIT	1
7	52281	TAIL PIPE TIP	1
8	42012	AIR FILTER ELEMENT	1
9	26068-00	HEAT SHIELD, TAIL PIPE EXTENSION	1
10	26001	HEAT SHIELD, BLANKET	1
11	52960	REAR HANGER CLAMP	1
12	52959	FRONT HANGER CLAMP	1
13	52461	CLAMP, EXHAUST, 2 1/2" HD	1
14	93161	CONICAL SEAL, EXHAUST OUTLET	2

Continued on page 6

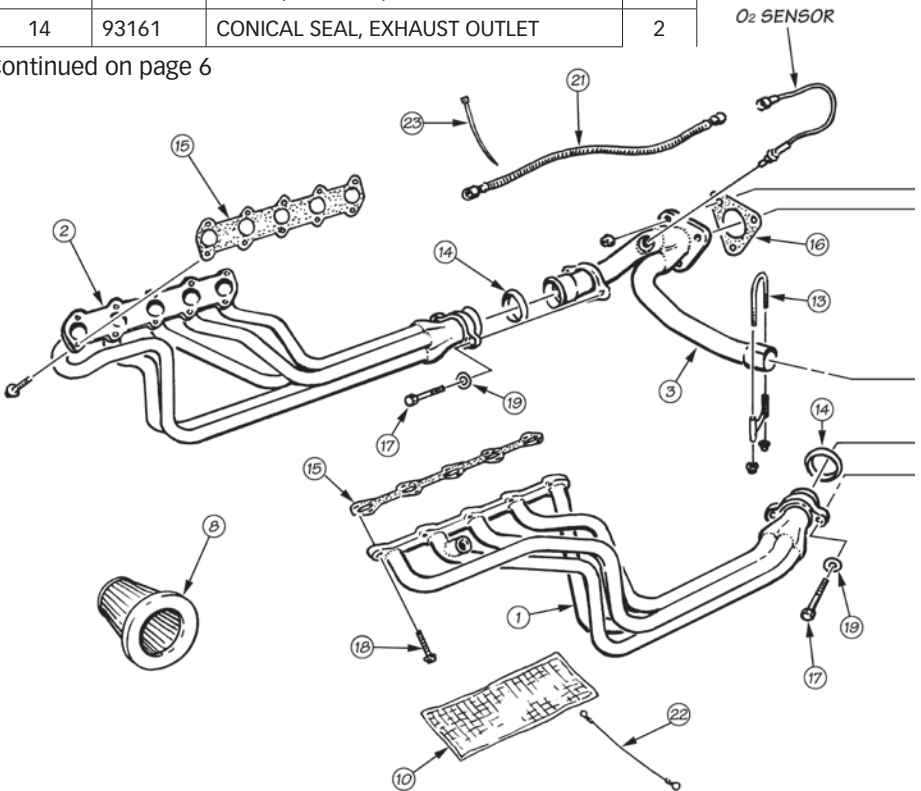

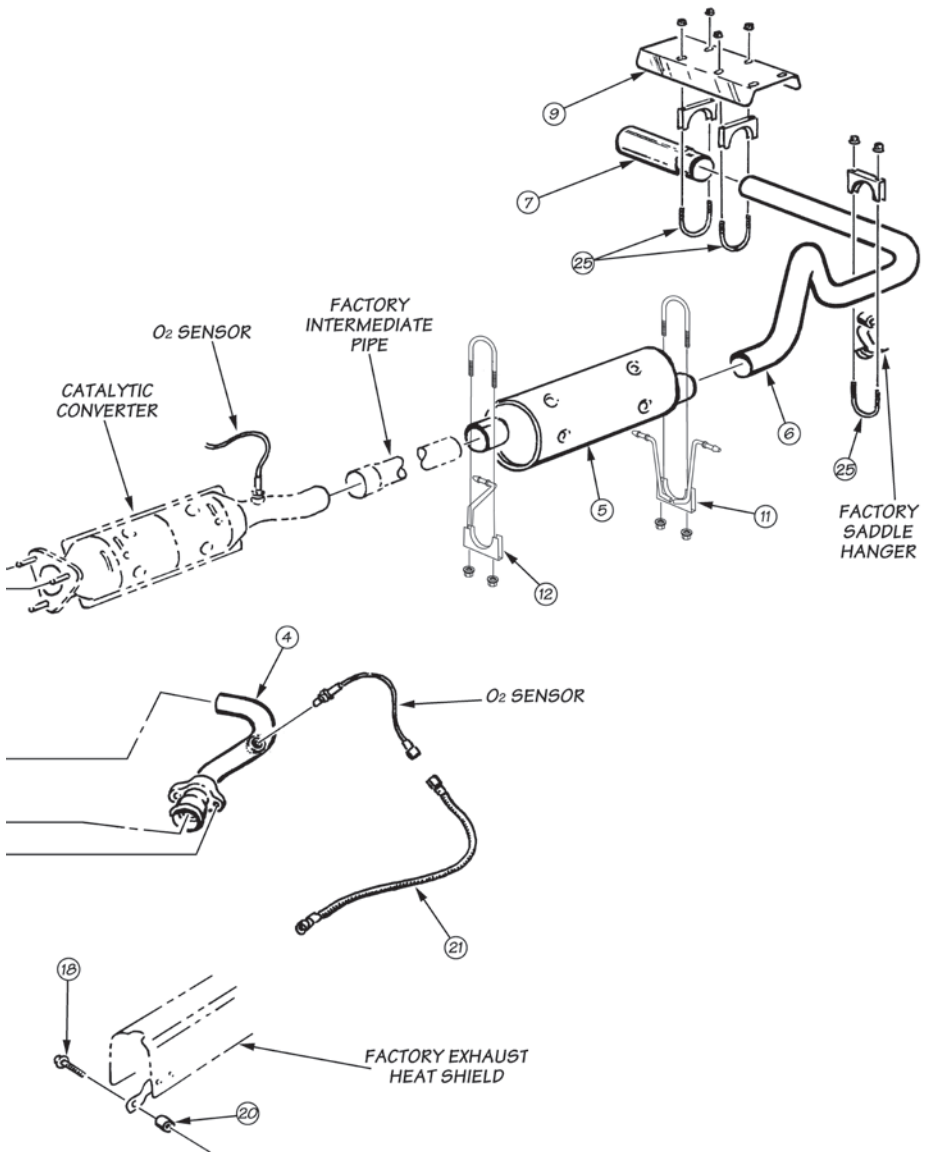

Item #	Part #	Description	QTY
15	93086	GASKET, EXHAUST MANIFOLD	2
16	93166	GASKET, CATALYTIC CONVERTER	1
17	91430	BOLT, 3/8" 16 x 1 3/4" Hex	4
18	91811	BOLT, 8mm x 1.25 x 35mm	18
	91810	BOLT, 8mm x 1.25 x 30mm	4
19	91402	WASHER, 3/8 SAE	4
20	26096	SPACER, Heat Shield	2
21	62200	WIRE EXTENSION, O ₂ Sensor	2
22	26013	WIRE TIES	3
23	62003	CABLE TIES, 13"	4
*24	66060-07	OTTOMIND Programmer (Optional)	**
25	52468	CLAMP, EXHAUST, 3 1/2"	3
26	53111	ADAPTER KIT, 3 BOLT FLANGE TO 3" SLIP FIT	1
27	52465	CLAMP, EXHAUST, 3" HD	1

* Not shown

** Not in system (optional)

Figure 2 Slip Fit Adapter Kit Shown

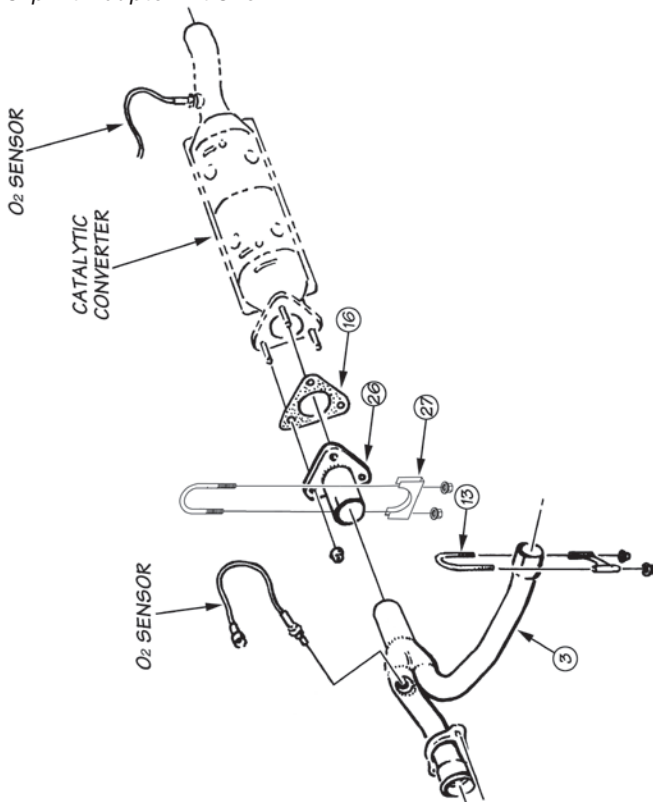

Section 1

TORQUETUBE MANIFOLDS

Power Pack Installation

For Stinger installation, proceed to **step 27**.

- 1.** Locate the oxygen sensors in each exhaust headpipe, downstream of the factory exhaust manifolds. Unplug the connectors and remove both the oxygen sensors. Mark the sensors for correct reinstallation.
- 2.** Locate the oxygen sensor downstream of the catalytic converter. This sensor should be unplugged, but does not need to be removed from the pipe.
- 3.** Disconnect the catalytic converter from the factory Y-pipe.

E-350 models - Remove the three (3) nuts from the factory catalytic converter flange, retain the nuts for reuse.

E-Super Duty or E-450 models - Some models are equipped with either a slip joint catalytic converter or three (3) bolt flange. If equipped with a slip joint converter remove the clamp between the factory Y-pipe assembly and catalytic converter. If vehicle is equip with a three (3) bolt flange catalytic converter remove the three (3) nuts from the factory catalytic converter flange, retain the nuts for reuse.

- 4.** Disconnect the headpipes from the exhaust manifolds and remove the Y-pipe assembly from the vehicle.
- 5.** On the driver's side of the engine, unscrew the EGR tube from the exhaust manifold with a 1¼" wrench and remove the EGR tube from the manifold.

- 6.** Pull out the dipstick and remove the small bolt that attaches the oil pan dipstick tube to the cylinder head. At the front of the engine, locate and loosen the nut that retains the dipstick tube bracket. Pull the dipstick tube up out of the engine block. Check to see if there is an O-ring on the tube. If not, the O-ring may be stuck inside the hole in the engine block. This O-ring should be retrieved if necessary and placed back onto the tube before reinstalling it.

- 7.** To remove the exhaust manifolds, use a wrench or socket to back the nuts away from the manifolds at least one turn, then use a 5mm 6 point socket to remove each stud from the head. As an alternate method, take the nuts off the studs, and then remove the studs.

- 8.** After the manifolds have been removed from the vehicle, remove any remaining studs from the heads. The studs must be removed from the heads in order to install the Banks TorqueTubes.

- 9.** Remove the large EGR adapter fitting from the left side factory manifold and install it onto the left Banks TorqueTube manifold. Reuse the original copper washer if equipped, between the manifold and adapter. Use anti-seize on the threads to prevent galling.

- 10.** On both sides of the vehicle, the exhaust heat shielding will need to be repositioned to allow the PowerPack components to be installed. Remove the bolt at the front of each heat shield and loosen the bolts at the rear on the cross member. Reattach each heat shield at the front using two 8mm bolts and 5/8" spacers provided. Retighten the two bolts at the rear of both heat shields.

Figure 3

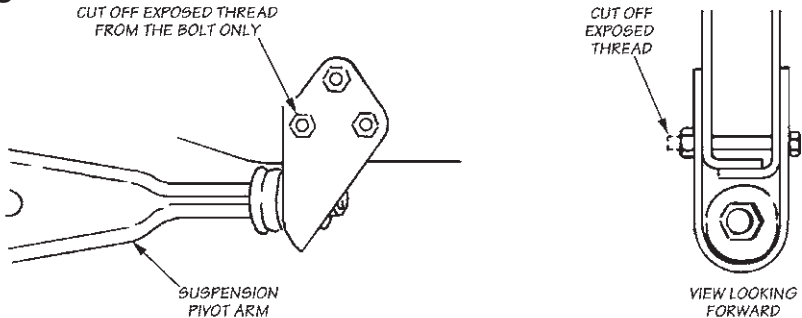

11. Locate a wire connector block mounted on a bracket on the left side frame rail. This connector must be relocated to allow clearance for the left side TorqueTube. Unbolt the wire connector from the bracket and roll it around to mount on top of the frame rail. Secure the connector to the frame rail using the tie wraps provided. Wrap the wires and connector with the heat shield blanket provided and secure with the wire ties.

12. Disconnect the positive cable from the starter. Remove the starter from the vehicle.

13. On the passenger side of the vehicle, cut off all excess thread protruding thru the nut on the forward bolt attaching the suspension pivot arm to the frame as shown in **Figure 3**.

Banks Torque Tube Installation

14. Inspect the exhaust mounting surfaces of the cylinder heads and clean away any deposits to assure proper sealing of the Banks TorqueTubes. Be careful when doing this as the cylinder heads are made from aluminum, and can be easily damaged. We recommend the use of a Scotchbrite® pad.

15. Place a small amount of anti-seize on the threads of each of the supplied manifold bolts. Use the new gaskets provided when installing TorqueTubes. Lift the Banks TorqueTube manifolds into place and install one or two bolts to hold them in position.

16. Attach the EGR tube to the adapter fitting in the Banks TorqueTube manifold. If necessary, loosen the fitting at the top of the EGR tube to allow the tube to be positioned properly.

17. Install the remaining bolts into the heads and tighten.

18. Reinstall the starter motor using the factory fasteners. Route the starter cable away from the manifold.

19. Inspect the exhaust manifold installation for any wiring, hoses, or carpet padding/insulation that are within 2-3 inches of the manifolds or EGR tubes. Tie wires away from the exhaust components as required. Trim away any carpet padding within 2 inches of the EGR tubes or exhaust components. On some models the oil cooler hoses may contact the header heatshield. Reposition the cooler hoses away from the heatshield using wire ties or by twisting the ends of the hoses at the connection to the oil filter base. See **Figure 4**.

Figure 4

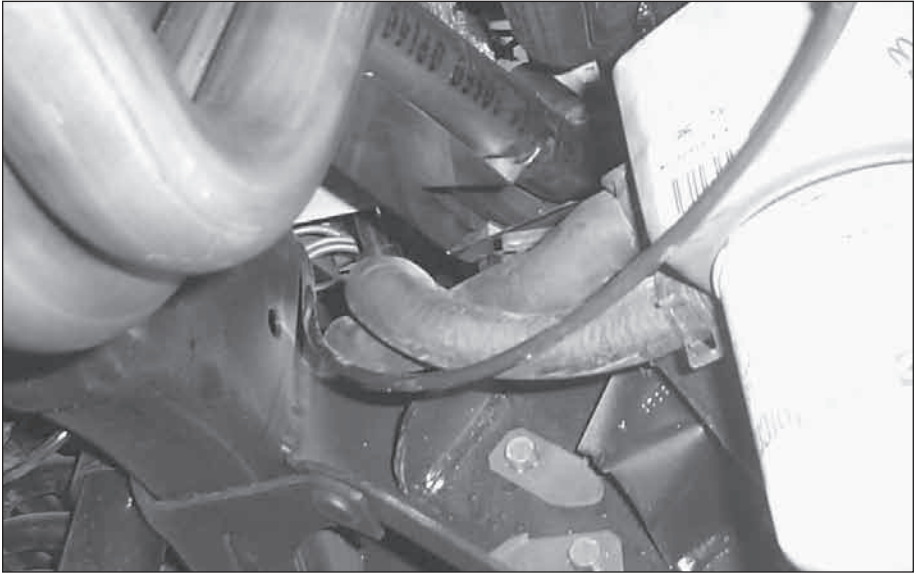

20. Make sure the O-ring is on the dipstick tube, and reinstall it into the hole in the engine block. Reattach the dipstick tube bracket to the cylinder head with the factory hardware.

21. Check to ensure that all wiring and hoses have adequate clearance to the manifolds. If rerouting is necessary, use the wire ties provided.

22. Place a conical seal onto the flared end of the Y-pipe extension and attach the extension to the left side TorqueTube with the $\frac{3}{8}$ " x $1\frac{3}{4}$ " bolts and washers. Slip a 2" muffler clamp onto the extension. Slip the Y-pipe onto the extension, and attach it to the right manifold with the $\frac{3}{8}$ " bolts, washers and conical seal. Make sure the slip joint between the left side Y-pipe extension and the right side Y-pipe is fully seated and snug the bolts on the clamp.

23. E-350 models – Place the new catalytic converter flange gasket onto the studs on the converter flange. Install the catalytic converter onto the Y-pipe flange. Reattach the frame hanger to the flange and tighten the three nuts.

E-Super Duty or E-450 models – Some models are equipped with either a slip joint catalytic converter or three (3) bolt flange.

Slip joint- slide a 3" clamp over the neck of the catalytic converter and slide the converter onto the Y-pipe. Install the hanger pin on the Y-pipe into the frame hanger. Position the converter straight with the frame rail and tighten the clamp.

Note: use a tailpipe expander or similar tool to facilitate in expanding the inlet of the catalytic converter pipe

Three bolt flange- locate the flange adapter kit. Slide a 3" clamp over the swedge end of flange adapter and install over the Y-pipe. Loosely tighten the clamp. Place the new catalytic converter flange gasket onto the studs on the converter flange. Install the catalytic converter onto the Y-pipe flange. Reattach the frame hanger to the flange and tighten the three nuts. See **Figure 2**.

Note: 2008 models-

Some models will need the Y-pipe (P/N 53110) length trimmed. Test fit the flange adapter, check for fitment when installing to the catalytic converter flange. If there is fitment problems remove the flange adapter and the Y-pipe. Measure 2 1/2" from the outlet of the Y-pipe to the front inlet and cut the Y-pipe. Reinstall the Y-pipe and flange adapter assembly. Install the catalytic converter onto the Y-pipe flange assembly. Reattach the frame hanger to the flange and tighten the three nuts.

24. Install and tighten the oxygen sensors into the threaded bungs provided on the Y-pipe and extension. Use a small amount of anti seize on the threads of the oxygen sensors. Be careful to not get any anti-seize on the sensor elements themselves. Plug the third oxygen sensor behind the converter back into its connector.

25. On the connector on the oxygen sensor and on the male connector on the sensor extension lead, remove the two index pins on the connector shell, by cutting or filing. Be careful to not damage the locking mechanism of the connectors. See **Figure 5**.

26. Plug the oxygen sensor extension leads included in the kit into the wiring harness where each sensor was previously connected, then plug the sensor lead into the extension. Secure the leads away from any pipes or moving linkages with the cable ties provided.

Figure 5

REMOVE INDEX PINS
FROM PLUGS

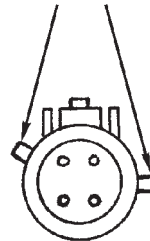

-END, SECTION 1-

Section 2

RAM-AIR® INTAKE

Unlatch the clamp that holds the two halves of the air filter housing together and remove the original filter. Install the Banks Ram-Air filter in place of the original.

-END, SECTION 2-

Section 3

MONSTER® EXHAUST

Stinger Installation

1. Disconnect and remove the factory tailpipe and muffler starting from the exhaust connection closest to the front of the muffler. Start from the rear and work forward, prying the pins from the rubber hangers, removing the tailpipe, then the muffler. If the slip joints will not come apart, use a torch to heat the connections until they separate, or cut the pipes apart with a saw or torch. Save all hardware and hangers as some items will be reused in the PowerPack installation.

2. For 2011 Models ONLY

Locate the factory intermediate pipe and cut 10 inches from the NON-swaged end of the intermediate pipe. See **Figure 6**.

3. Place the single pin 3" hanger clamp onto the Dynaflow Muffler inlet. Install the dual hanger pin 3.5" hanger clamp onto the muffler outlet. With the hanger pins facing the front of the vehicle.

4. Install the Banks Dynaflow muffler and hanger clamps onto the catalytic converter outlet. Position the pin hangers into the rubber hangers on the frame, and adjust the rotation of the muffler as necessary to position the hanger pins level in the vehicle.

Make sure that the hangers are hanging forward. This will allow the hangers to swing as the exhaust system expands while the engine is running. The clamps should be on the arch of the slots punched on the muffler.

5. Lift the Banks Monster tailpipe up and over the axle and insert the Banks Monster tailpipe into the end of the muffler. Set the tailpipe into the factory hanger saddle. Clamp the pipe to the saddle using a 3½" clamp. Level the tip of the tailpipe and tighten all clamps.

6. Mount the floor heat shield and polished tip onto the pipe using the 3½" clamps provided.

7. Lower the vehicle and reconnect the battery cables. Start the engine and listen for any exhaust leaks. Tighten bolts or clamps to correct any leaks or make adjustment as required. It is recommended that tack welds be placed on all slip connections to prevent slippage.

Note: The vehicle exhaust may smoke upon initial start-up. This is normal, as grease used in the tube-bending process burns out of the pipes.

-END, SECTION 3-

Figure 6 - 2011 models only

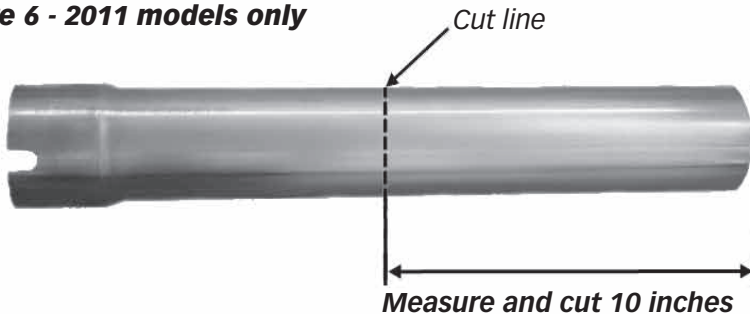

Section 4

CLEANING AND OILING THE BANKS RAM-AIR FILTER

Notification

The Banks Ram-Air Filter comes pre-oiled and no oiling is necessary for initial installation.

Use Banks Ram-Air Filter cleaning system (part#90094), available from Gale Banks Engineering to service the Air Filter. Follow the instructions included with the cleaning system to clean and re-oil your Banks Ram-Air Filter.

1. PRE-CLEANING

Tap the element to dislodge any large embedded dirt, then gently brush with a soft bristle brush. *NOTE: If complete cleaning is not practical at this time, reoil the element and reinstall in your vehicle.*

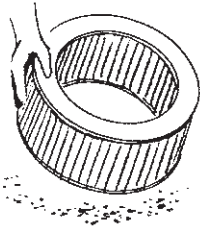

2. SPRAY-ON CLEANING

Spray Banks air-filter cleaner liberally onto the entire element and let soak for 10 minutes.

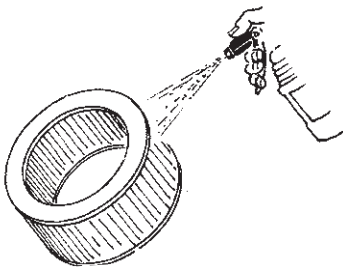

PAN CLEANING

Large air-filter elements can be rolled or soaked in a shallow pan of Banks air-filter cleaner. Remove immediately and let soak for approximately 10 minutes.

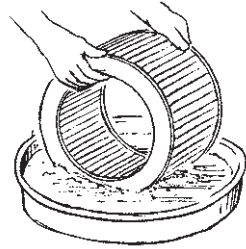

3. CLEANING HINTS

Use only Banks air-filter cleaner. No gasoline cleaning, No steam cleaning, No caustic cleaning solutions, No strong detergents, No high-pressure car wash, No parts cleaning solvents. Any of these Nos can cause harm to the cotton filter media plus SHRINK and HARDEN the rubber end caps.

4. RINSE OFF

Rinse off the element with low-pressure water. Tap water is okay. Always flush from the clean side to dirty side. This removes the dirt and does not drive it into the filter.

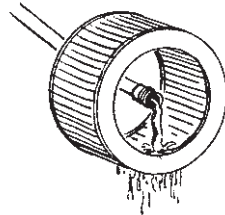

5. DRYING HINTS

Always dry naturally. After rinsing, shake off all excess water and let the element dry naturally.

DO NOT USE COMPRESSED AIR – DO NOT USE OPEN FLAME – DO NOT USE HEAT DRYERS!

EXCESS HEAT WILL SHRINK THE COTTON FILTER MEDIA. COMPRESSED AIR WILL BLOW HOLES IN THE ELEMENT.

6. AEROSOL OILING

After cleaning air filter always re-oil before using. Spray Banks Ram-Air filter oil down into each pleat with one pass per pleat. Wait 10 minutes and re-oil any white spots still showing.

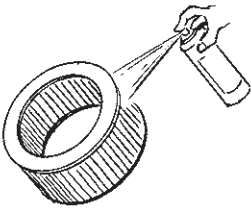

7. OILING HINTS

Never use a Banks Ram-Air filter without oil (the filter will not stop the dirt without the oil). Use only Banks Ram-Air filter oil. Banks air-filter oil is a compound of mineral and animal oil blended with special polymers to form a very efficient tack barrier. Red dye is added to show just where you have applied the oil. Eventually the red color will fade but the oil will remain and filter the air.

NEVER USE Automatic Transmission Fluid. NEVER USE Motor Oil. NEVER USE Diesel Fuel. NEVER USE WD40, LPS, or other light-weight oils.

8. REINSTALL

Reinstall your Banks Ram-Air filter element with proper care. Make sure the element seats properly in the filter case. Install the cover making sure it's in the right position. Tighten all the nuts, bolts, screws or clips to factory specifications.

9. DO NOT DISCARD

Affix the "Do Not Discard" sticker to the filter case (included with every Banks replacement element). Make sure you put the sticker in a highly visible place to alert your mechanic not to discard.

10. PERFORMANCE HINTS

Service every 50-100,000 miles on street-driven applications. Service more often in offroad or heavy-dust conditions. If an air-filter restriction gauge is installed, then change the element when the air-filter restriction reaches 18"/H.O.

CAUTION! Extremely fine dust from agriculture or offroad use will pull the oil from the element. Frequent reoiling of the element's clean side might be required. Completely service when practicable. For extra protection use an air-filter sealing grease on rubber ends of the element. Service only with Banks air-filter cleaner and Banks air-filter oil.

-END, SECTION 4-

NOTES

NOTES

Gale Banks Engineering
546 Duggan Avenue • Azusa, CA 91702
(626) 969-9600 • Fax (626) 334-1743

Product Information & Sales: (888) 635-4565

bankspower.com