

FORD SUPERDUTY- WITH OE FENDER FLARES REAR MUD GUARD - INSTALLATION INSTRUCTIONS

Please read instructions thoroughly before installation.

Tools Required

- Short Phillips screwdriver
- Drill-1/8" Drill Bit
- Center Punch/ Hammer
- Marking Utensil (fine tip marker, grease pencil, ect.)

Package Contents

- Driver & Passenger Side Rear Mud Guards
- #10 SEM Screws (qty. 4)
- #10 x 1.5" Screw (qty. 2)
- U-Clip (qty. 6)
- Paint Protection Film (1 set)
- Instruction Sheet

PAINT PROTECTION FILM - INSTALLATION

NOTE: The Paint Protection Film is a precut template of film used to protect the mud guard mounting surfaces of your fenders against wear. The templates (left and right side) can be removed from the backing liner by folding the liner at the center cut of the template, separating the film sides and peeling the film templates from the backing liner.

1. Position mud guard on fender to indicate placement location of paint protection film.
2. Clean the placement area of fender with a clean cotton cloth and a petroleum distillate based cleaner such as DuPont Prep-Sol Brand Solvent Cleaner or 3M Brand Adhesive Cleaner and dry.
3. Mix a wetting solution of 1 pint of water with 4 drops of liquid dishwashing detergent.
4. Mark correct position of film by placing mud guard against fender.
5. Remove protection film from liner and flood adhesive side of film with wetting solution (use a spray bottle or sponge).
6. Thoroughly wet film placement location of fender with wetting solution.
7. Position the adhesive side of film on fender and flood with wetting solution.
8. Check location of film with mud guard and reposition as necessary.
9. Using a sponge, squeegee any air bubbles and wrinkles from film.
10. Allow film to dry before installing mud guard.

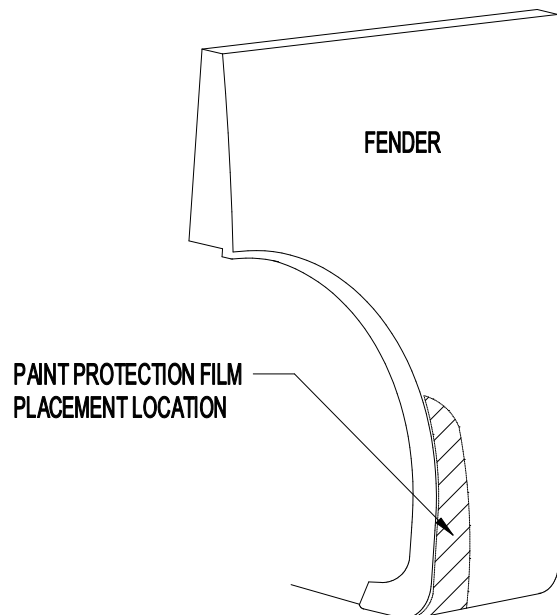

MUD GUARD INSTALLATION

NOTE: It may be necessary to remove the wheels before mud guard installation.

1. Remove plastic fastener from location B and discard.
2. Remove the existing fastener from location A (Figure 1).
3. Install a u-clip over fender sheet metal and align with existing hole at location B (Figure 1).
4. Attach the mud guard to the rear fender with existing fastener at location A, check fit and parallel. Adjust accordingly before tightening.
5. Install a #10 SEM screw at location B.
6. Install the long 1.5" #10 screw at location C by screwing the fastener into the mud guard. The screw installs thru mud guard, thru the slot in the fender and into a u-clip on the top-side of the fender. NOTE: The u-clip is used as a nut and installs on the top-side of the fender.
7. Using the mud guard as a template, mark and drill an 1/8" hole at location D. Install a #10 SEM screw thru mud guard, fender liner and into a u-clip on the back side of the fender liner. NOTE: The u-clip is used as a nut and installs behind the fender liner.

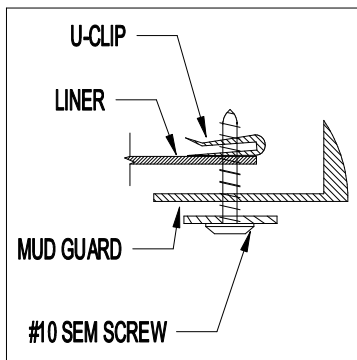

Figure 2

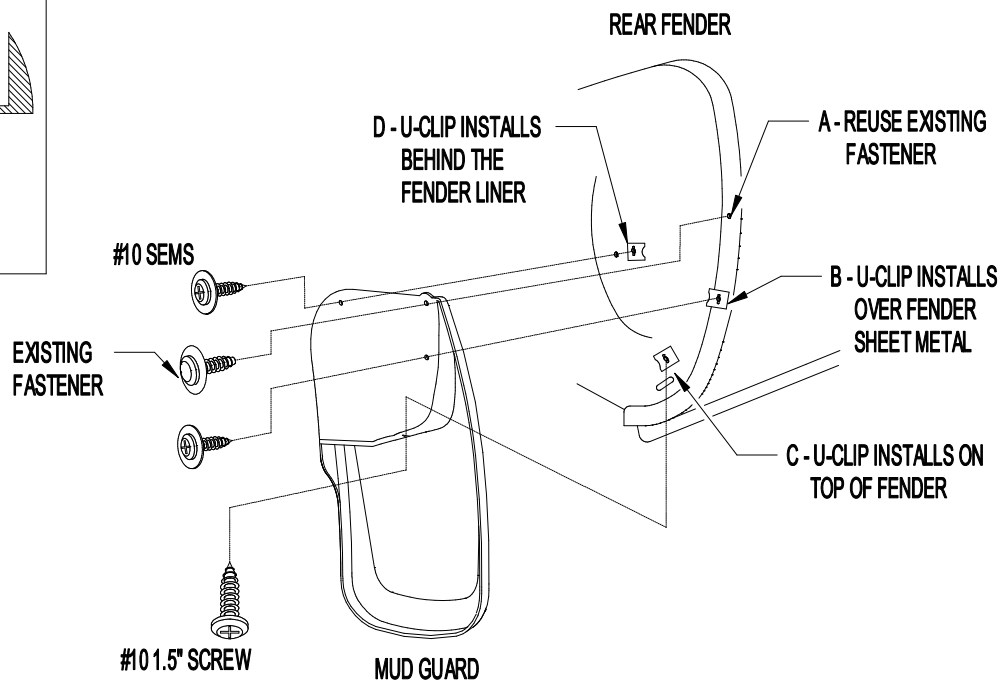

Figure 1

PAINTING INSTRUCTIONS

1. Clean mud guard with soap and water to remove dirt and other contaminants.
2. Sand painting surface with 320 grit sand paper.
3. Apply a coating of flexible primer-adhesion promoter.
4. Apply a flexible paint as directed by the paint manufacturer.